

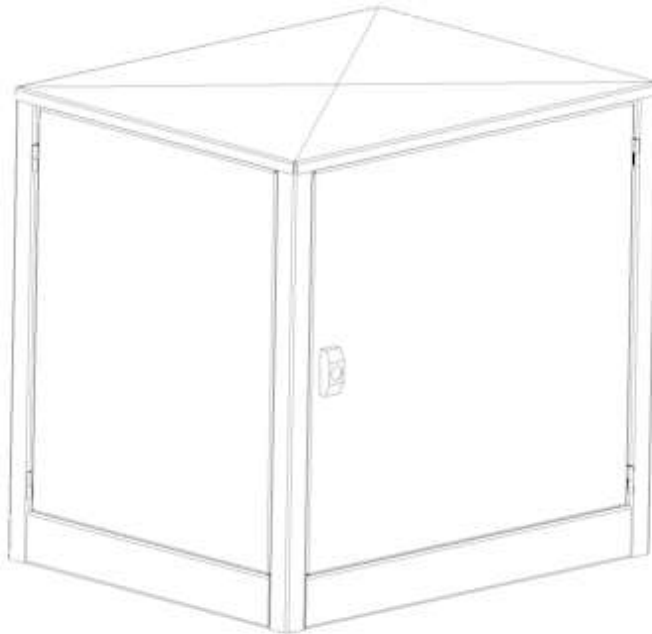

# MODEL 611x SERIES Wedges & Bollards Hydraulic Pumping Unit (HPU)

## INSTALLATION MANUAL



### **B&B ARMOR**

#### **CORPORATE OFFICE & TECHNICAL SUPPORT:**

5900 S. Lake Forest Drive

Suite 230

McKinney, TX 75070

PHONE: 800-367-0387

FAX: (972) 385-9887

E-mail: [info@bb-armr.com](mailto:info@bb-armr.com)

[techsupport@bb-armr.com](mailto:techsupport@bb-armr.com)

**MADE IN THE USA**



Your safety is extremely important to us. If you have any questions or are in doubt about any aspect of the equipment, please contact us.

## INTRODUCTION

### Welcome!

Congratulations on your purchase of a B&B ARMR Hydraulic Pumping Unit (HPU). In addition to providing detailed operating instructions, this manual describes how to install, maintain, and troubleshoot your HPU. If you require additional assistance with any aspect of your installation or operation, please contact us.

We have years of experience in all aspects of perimeter security and related disciplines, and our products are used throughout the world to control access and to protect people, equipment, and facilities. We offer a broad range of vehicle barrier and related security services:

- Turnkey installations
- Routine barrier preventative maintenance or emergency repairs (including work on non-B&B ARMR products)
- Spare or replacement parts
- Custom designs or special installations
- Equipment upgrades (modernize your old equipment with state-of-the-art hydraulics and control systems)
- Ancillary security equipment such as security guard enclosures, card readers, security lighting, and many other security related products.
- Technical support via telephone and possible on site support with advanced scheduling.

## Safety

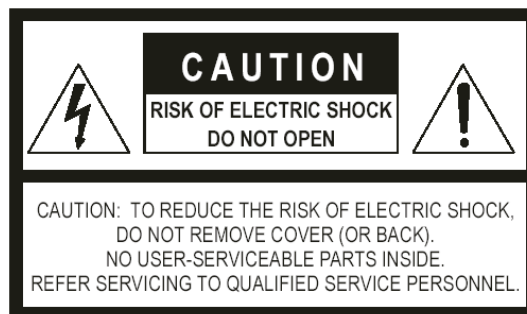

## SYMBOL MEANING:



The lightning flash with arrowhead symbol, within an equilateral triangle, is intended to alert the user to the presence of non-insulated "dangerous voltage" within the product's enclosure that may be of sufficient magnitude to constitute a risk of electric shock to persons.



The exclamation point within an equilateral triangle is intended to alert the user to the presence of important operating and maintenance (servicing) instruction in the literature accompanying the product.

B&B ARMR does not assume responsibility for injury to persons or property during installation, operation, or maintenance. As the user, you are responsible for correct and safe installation, operation, and maintenance of this equipment. Users must follow the specific instructions and safety precautions located in this manual. In addition they must: Follow the safety standards of the Occupational Safety and Health Administration (OSHA), as well as other applicable federal, state, and local safety regulations and industry standards and procedures. For installation outside the United States, users must also follow applicable international, regional, and local safety standards. Engage only trained and experienced staff to install, operate, and maintain the equipment. Ensure that all repairs are performed correctly, using properly trained technicians and the correct tools and equipment.



This HPU comes with a power ON/OFF switch. Although this switch does cut the power to the motor and various other devices, always use correct lock-out and safety procedures when servicing the unit. This unit is designed to be operated with the covers in place. Extreme caution should be used when operating without covers.

Additional system safety devices may be included with this barrier system:

- Vehicle loop detector(s) – Safety loop
- Traffic arms
- Traffic lights
- IR beams
- Safety edges

---

## How to Contact Us

If you have any questions or experience any problems with your vehicle barrier—or if we can help you with any other facility security issues—please contact us directly at:

**Corporate/Tech Support:**  
**B&B ARMR**  
5900 S. Lake Forest Drive, Suite 230  
McKinney, TX 75070 USA  
Telephone: (972) 385-7899  
Toll Free: (800) 367-0387  
Fax: (972) 385-9887  
**E-mail: [info@bb-armr.com](mailto:info@bb-armr.com)**  
**[techsupport@bb-armr.com](mailto:techsupport@bb-armr.com)**

## System Installation Record

To assist in documenting the products installed in your system, please take a minute to record the following reference information. This information can be located on the blue B&B ARMR model number plate located on the product.

Additional columns are added for your convenience in documenting other components in the system.

Site:			
Job #:			
Date:			
Serial Number:			
Model Number:			
Voltage:			
Phase:			

## Table of Contents

<b>INTRODUCTION.....</b>	<b>ii</b>
<b>Safety.....</b>	<b>ii</b>
<b>How to Contact Us .....</b>	<b>iv</b>
<b>System Installation Record.....</b>	<b>iv</b>
<b>1 ORIENTATION .....</b>	<b>6</b>
<i>1.1 Overview .....</i>	<i>6</i>
1.1.1 Electrical Control Box .....	7
1.1.2 Flow Control Valve .....	7
1.1.3 System relief Valve .....	7
1.1.4 Tank Weldment .....	7
1.1.5 Oil Site Gauge .....	7
1.1.6 Manifold Block.....	7
1.1.7 Pressure Switch.....	8
1.1.8 Hand Pump .....	8
1.1.9 Pressure gauge .....	8
1.1.10 Accumulator.....	8
1.1.11 Pump .....	8
1.1.12 Electric Motor .....	8
1.1.13 EFO Valve and Coil.....	8
1.1.14 Base Filter Assembly .....	8
1.1.15 Directional Control Valve.....	9
1.1.16 Cabinet .....	9
1.1.17 Options.....	9
<b>2 INSTALLATION .....</b>	<b>9</b>
2.1 Introduction.....	9
2.2 Site Preparation .....	10
2.3 Hydraulic Connections.....	13
2.4 Electrical Connections .....	15
2.5 Proximity Switch Connection .....	15
2.6 Final Pre-operation Checklist.....	15
2.6.1 Start up procedure of Hydraulic Pumping units .....	16
2.6.2 Line Purging Procedure after Start-up .....	16
2.6.3 Pressure Adjustment .....	16
<b>3 TROUBLESHOOTING .....</b>	<b>17</b>
<b>4 WARRANTY.....</b>	<b>19</b>
<b>5 APPENDIX.....</b>	<b>19</b>
5.1 Simplified Standard Hydraulic Diagram .....	19

5.2 Typical Bollard Hydraulic Flow Diagram.....20  
 5.3 Electrical Field Wiring Diagram.....21

# 1 ORIENTATION

## 1.1 Overview

The model 611X hydraulic pumping unit is designed to operate hydraulic barriers that require medium pressure and high flow. The electric motor comes on any time the system pressure drops below the set point and the level of fluid is adequate. It is connected directly to a hydraulic pump which operates independently from the signal command. The oil from the pump is drawn through a filter and directed into a directional control valve. The flow control valve monitors the operational speed of the barrier.

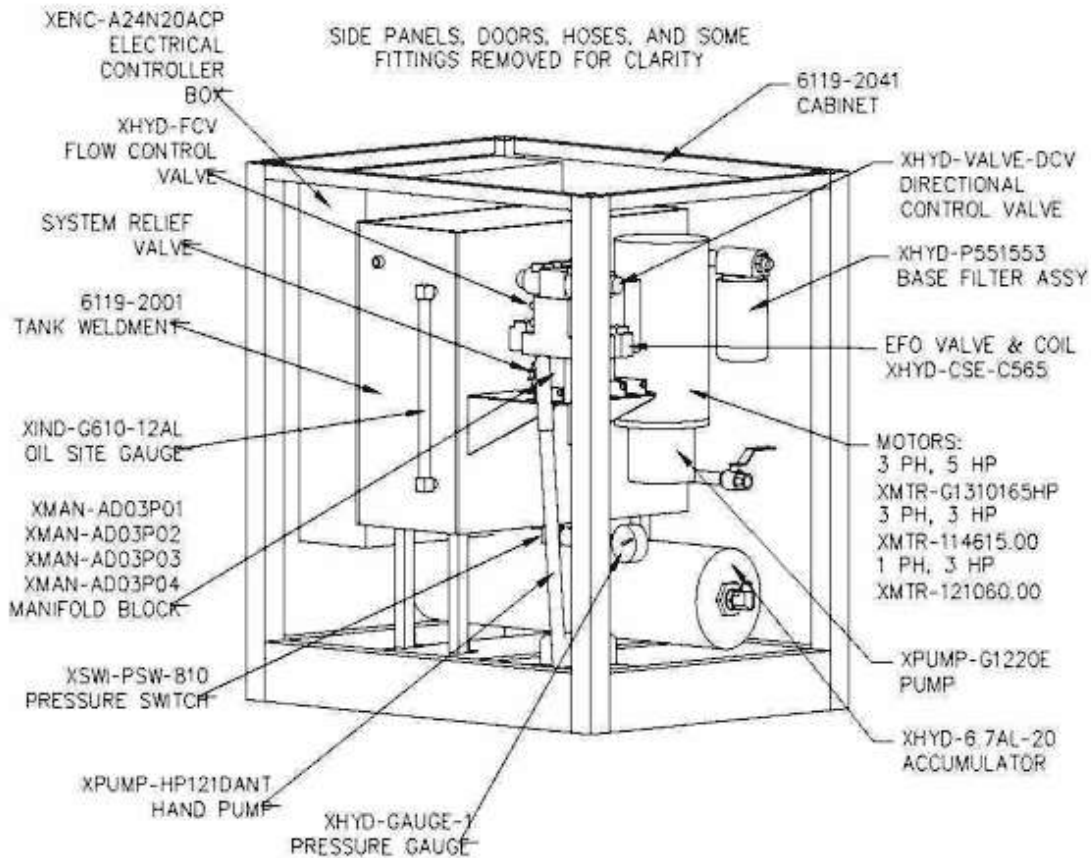

Figure 1 Orients you to the basic components of the 6118 & 6119 series HPU:



The HPU contains **HIGH VOLTAGE** components that can cause serious injury or death. Only trained service technicians should attempt any repair. Ensure at all times that proper safety lock-outs, barrier safety braces and all other safety systems are in place prior to any maintenance or service.



The HPU is a hydraulic system that can be under extreme pressure. Caution should be used when working in and around unit without proper covers in place.

### 1.1.1 Electrical Control Box

The control box houses the electronic controls in the HPU. The program installed in the PLC varies based on the barrier style and application.

The power switch should be turned off any time the unit is serviced. Do not restore power to the unit until all traffic and pedestrians have been cleared from harm's way.

### 1.1.2 Flow Control Valve

The flow control valve(s) are located on the manifold and are used to control the amount of flow of hydraulic fluid both to and from the barrier under control. This in turn sets the speed of operation of the barrier. The lower flow control valve controls how fast the gate travels, while the upper control valve restricts how fast the barrier is opened.

### 1.1.3 System relief Valve

The system relief valve enables the system to be de-pressurized during maintenance and service operations.

### 1.1.4 Tank Weldment

The tank reservoir holds the hydraulic fluid that is not under pressure. The nominal capacity of the tank is 20 gallons (40 gallons on the 6117). B&B ARMOR recommends the use of environment-friendly oil such as Mobil EAL 224 in all of our hydraulic systems.

### 1.1.5 Oil Site Gauge

The oil site gauge gives an easy indication of the fluid level in the reservoir tank without requiring the removal of the top cover.

### 1.1.6 Manifold Block

The main manifold block routes the pressurized hydraulic fluid to the various locations in the hydraulic system via control valves.

### 1.1.7 Pressure Switch

Adjustment of the pressure switch determines the system pressure. This switch controls the motor to maintain the system pressure. See pressure switch adjustment process to ensure proper system pressure.

### 1.1.8 Hand Pump

In case of electrical failure, a manual hand pump is provided to enable the system to be pressurized to operate the unit once the directional control valve is shifted. The valve should be shifted and then manually stroke the hand pump until the barrier has closed the roadway.

NOTE: the manual pump is used in case of power loss when the barrier must be moved.

### 1.1.9 Pressure gauge

The pressure gauge shows the actual HPU system pressure. Standard operations should be less than 2000 PSI. If higher pressure is required, please verify operation with B&B ARMR technical support.

### 1.1.10 Accumulator

The accumulator acts as a pressure reservoir to store pressurized fluid. The electric pump pressurizes the accumulator and the accumulator provides a high volume of pressurized fluid in a short period of time.

### 1.1.11 Pump

The pump is mechanically connected to the electric motor and provides the required pumping pressure to charge the accumulator. The pump typically provides fluid at a rate of 2 GPM.

### 1.1.12 Electric Motor

The electric motor drives the hydraulic pump. The 611x series HPUs are provided with a variety of motor voltages. Ensure correct voltages prior to initial operation.

### 1.1.13 EFO Valve and Coil

The Emergency Fast Operation (EFO) valve bypasses the flow control circuit and allows the system to provide full flow at highest system pressure. This operation is intended to move the barrier in the deployed position in a short amount of time. All safety inputs are ignored during EFO operation.

### 1.1.14 Base Filter Assembly

The filter assembly is used to filter contaminants from the hydraulic oil during operation. Routine maintenance is required to replace the filter and ensure system is kept free of contamination. The strainer and spin on filter should be replaced as part of normal maintenance whenever the oil is serviced. B&B ARMR recommends the use of environment-friendly oil such as Mobil EAL 224 in all of our hydraulic systems.



### 1.1.15 Directional Control Valve

The directional control valve operates the unit in the normal operation mode. It changes to allow fluid to pass to the barrier for deployment.

### 1.1.16 Cabinet

The pump cabinet houses the pumping unit components. The hydraulic pump enclosure is weather-tight and lockable. Typical environmental operation is between 0 F and 110 F. Typical enclosure is designed to provide a NEMA level 3R rating.

### 1.1.17 Options

The 611X series HPU's are available with a broad array of options and field installed kits. Consult your ordering documentation to determine whether your system has the optional equipment.

- Multiple manifolds to drive multi-lane solutions.
- Multi-loop detection components for a variety of programmable modes of operation.
- A traffic control gate arm to warn the vehicle operator. This arm is positioned in front of the gate and does not rise until the gate is fully open, and it closes before the gate starts to close.
- Red/amber traffic lights. The light remains red if the gate is in any position except fully open.
- Infrared safety beams to detect pedestrian traffic or as an additional vehicle sensing device.

## 2 INSTALLATION

### 2.1 Introduction

This section of the manual describes the procedure to set-up and configure a 611X Series HPU for first-time operation. The product ships from the factory tested and ready for deployment following these steps.

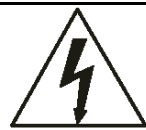

**DANGER:** High voltage electrical components are located in the Hydraulic Pumping Unit (HPU) cabinet. Service by qualified technicians only.



**CAUTION:** Heavy components and pinch points are present in this product. Use extreme care and proper lifting techniques when servicing this unit.

**NOTE:** The hydraulic hoses are constructed with JIC fittings to allow removal and installation without sealant. Care should be used when disconnecting the pressure side of the hose to insure the pressure has been released prior to disconnecting the

**fitting. The pressure can be relieved by activating the down control button and visually watching the cylinder close. If the hydraulic cylinder does not fully close, the hose is still under pressure and must not be serviced until the directional control valve has been manually released and the cylinder can be verified to be in a fully released position and the barrier is in the lowered (no pressure) position.**

## 2.2 Site Preparation

The hydraulic pumping unit should be securely fastened prior to operation. The feet are designed to accept a standard concrete anchor for mounting. If the unit is put on a steel structure, it should be mechanically connected to prevent unnecessary vibration. The unit is designed with a large open area to allow the positioning of conduits. Normal construction sequence would have the electrical, control and hose conduit running together before turning up out of the concrete slab. The pumping unit is then positioned over the conduits and anchored into place. The power and control conduits terminate into the electrical box. The hydraulic conduit should not extend beyond the height of cabinet base. This conduit elevation will allow the hose freedom to move during the application of pressure, without scraping the sides of the hose against a sharp top edge of the conduit.

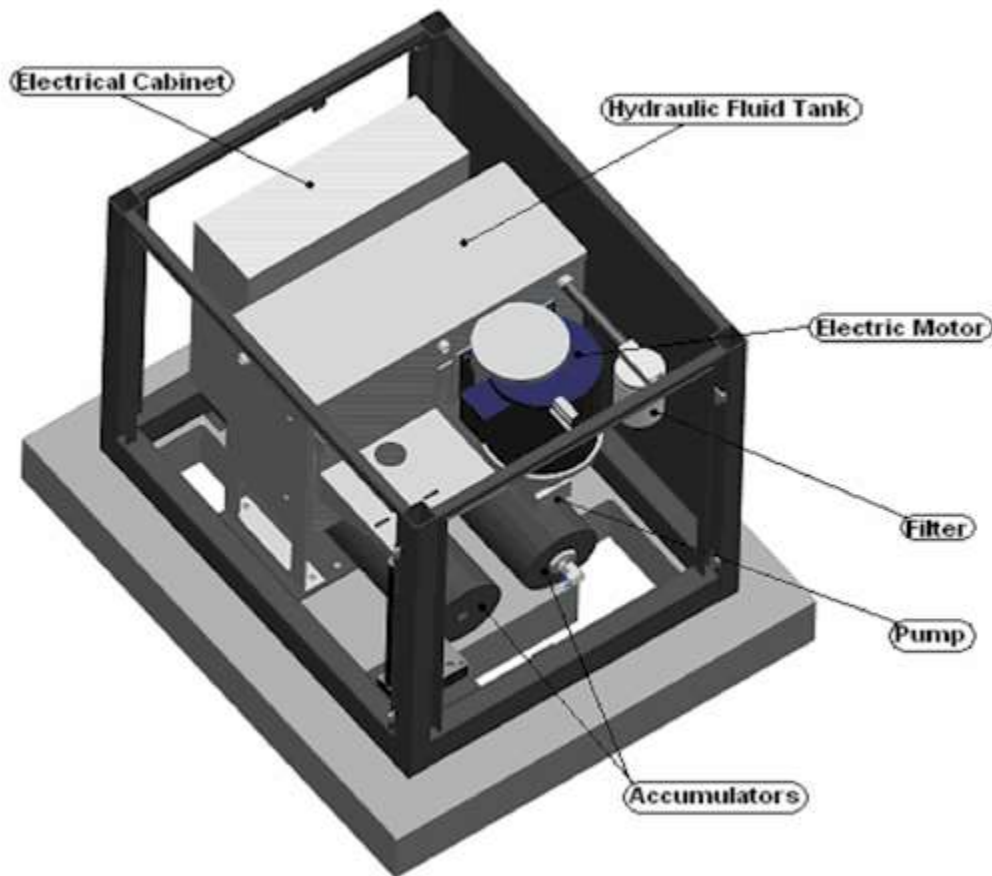

**Figure 2 Angled overview of 6118 & 6119 HPU on foundation**

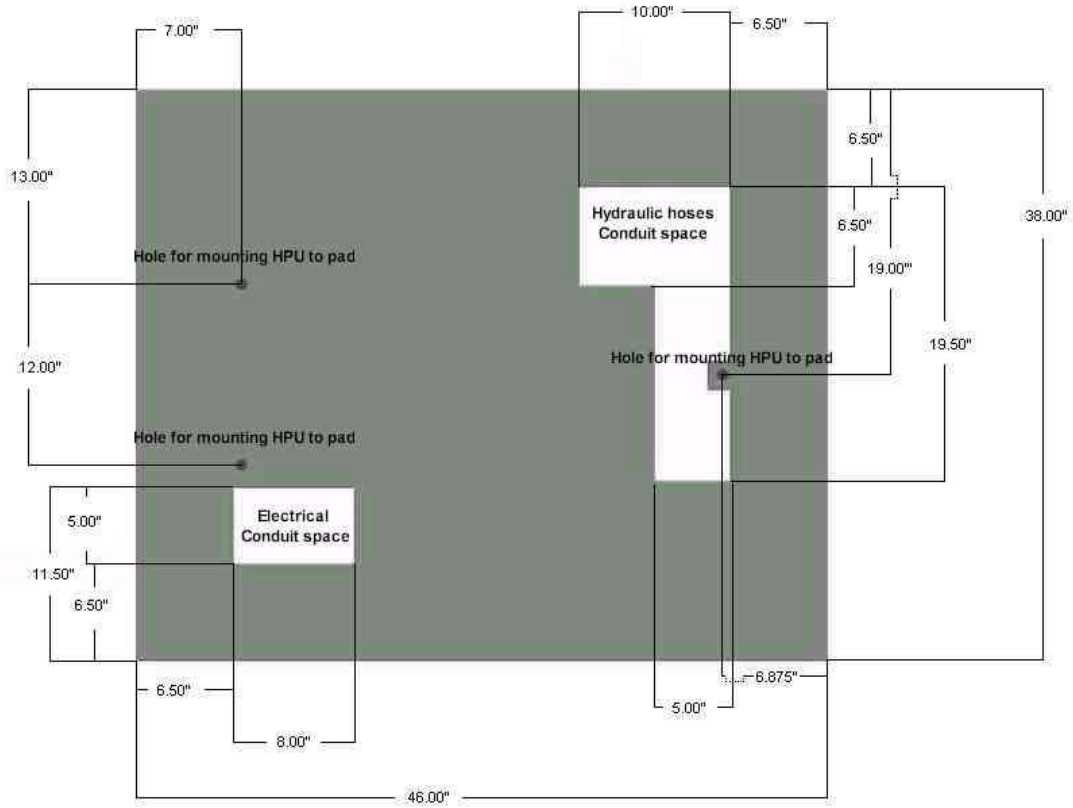

Figure 3 Dimensions of concrete pad with conduit spaces for 6118 & 6119

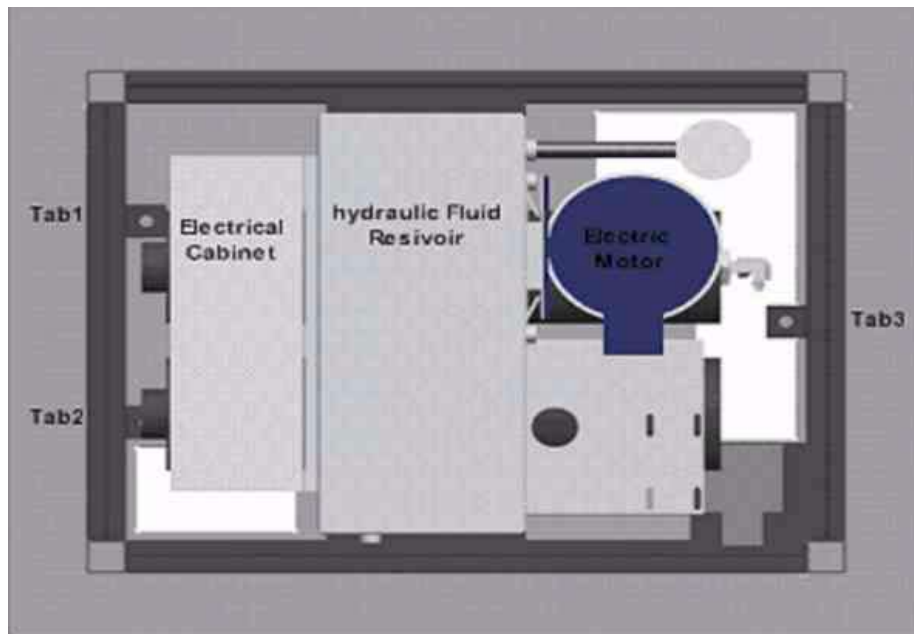

Figure 4 Top view of 6118 & 6119 HPU showing mounting tabs

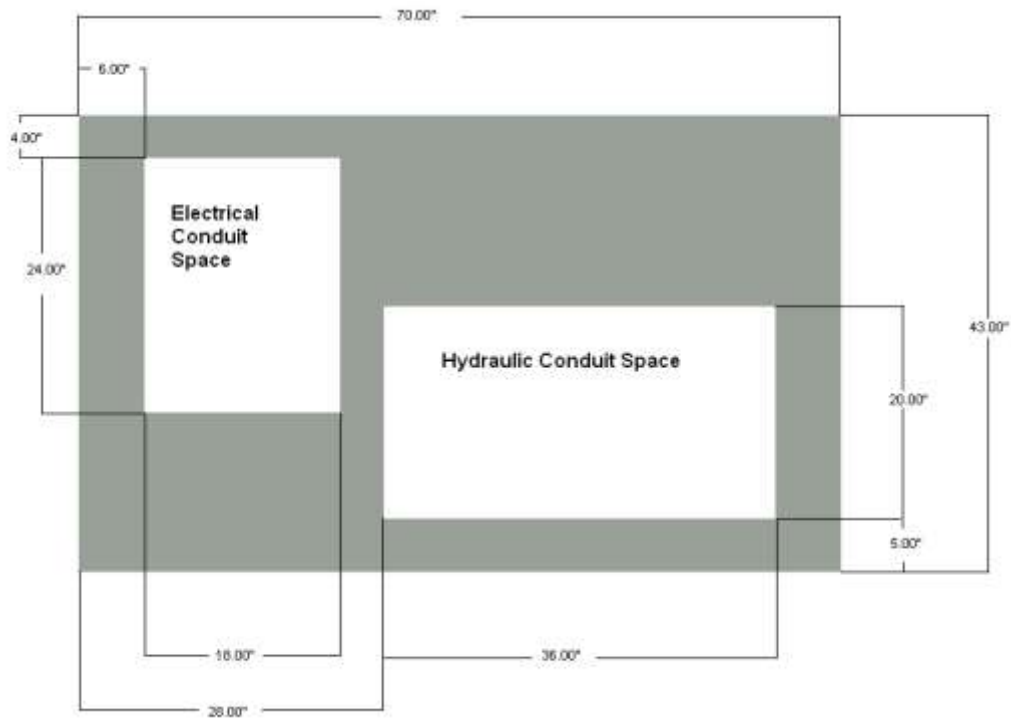

Figure 5 Dimensions of concrete pad with conduit spaces for 6117

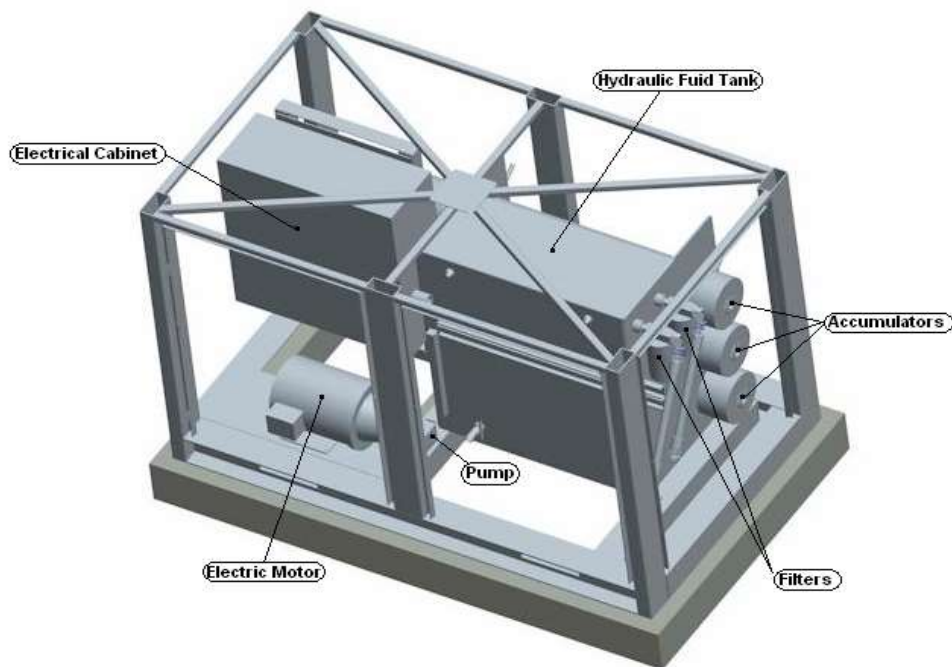

Figure 6 Angled overview of 6117 on foundation

## 2.3 Hydraulic Connections

Connect hydraulic lines through conduit to cylinder connection using JIC fittings. As a reference, use environmentally safe oil Mobil EAL 224 or equivalent when adding hydraulic oil to the HPU.



**CAUTION:** The hydraulic system when in operation is under extreme pressure. Verify pressure on the barrier is completely relieved prior to removal of any hydraulic fittings.

### *Cylinder operated type barriers (Model 820, B30):*

Hydraulic field connections may be made to either port A or port B on the main manifold. Systems using a single barrier per lane should connect the hose going to the cylinder to raise the barrier to the manifold port labeled B. This enables the flow controls on the EFO manifold to be positioned for easier access. The second hose used with the 820 model is plumbed back from the cylinder to the reservoir through the NPT coupling at the top of the tank. (Installer is to provide the appropriate fitting for the connection to the tank). The unused pressure ports will be plugged from the factory. The figures below show a typical 2 lane manifold and locations of connection points and flow controls. Use care in tightening hydraulic fittings. Extreme torque is usually not required and will damage fitting if done improperly.



**Figure 7 Hydraulic Connections**



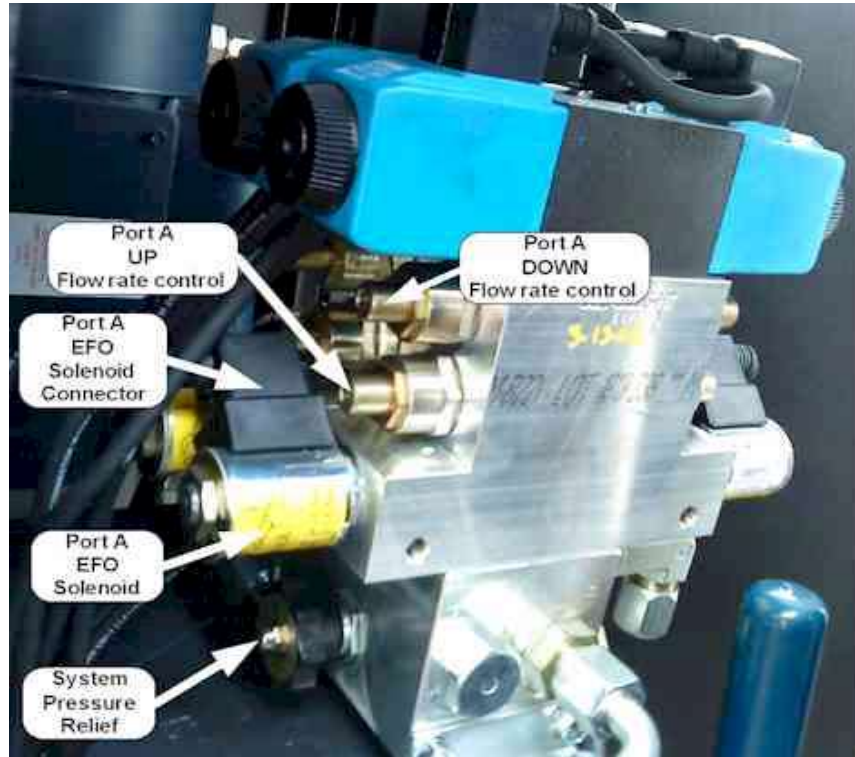

Figure 8 HPU with EFO Manifold Flow Control-Port A

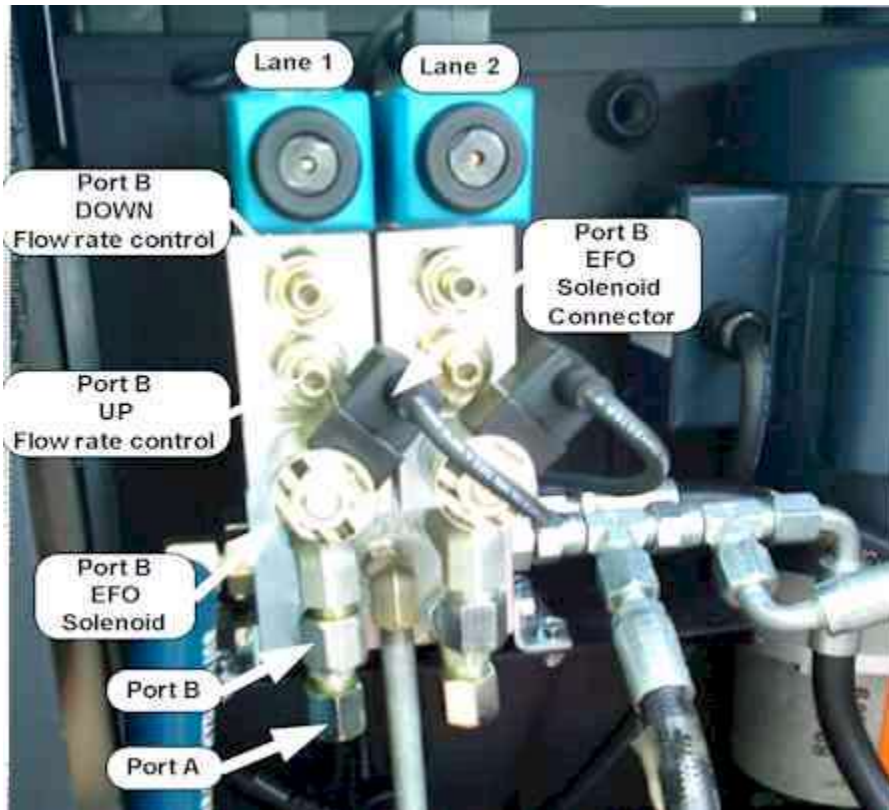
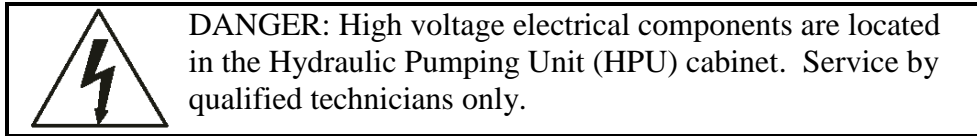

Figure 9 HPU with EFO Manifold Flow Control-Port B

## 2.4 Electrical Connections



The electrical connections required for proper operation include power and control. The power is required to drive the motor and power the PLC while the control voltage is 24VDC and is used to power the inputs. All of the electrical wiring should be fed through conduits in the hydraulic pumping unit into the electrical control box mounted in the front of the hydraulic unit. The power feed is connected to terminals L1, L2, L3, Neutral and Ground. Specific control connections may be found by referencing the control circuit drawing supplied in the HPU.

The motor will run any time the fluid level is adequate and the system pressure is below its set point, to charge the accumulator. The motor drives the hydraulic pump directly through a coupling and transports the oil to the manifold and into the directional control valve. Depending on the command, the flow will either run the hydraulic motor to open or close the gate.

## 2.5 Proximity Switch Connection

If your barrier is equipped with a proximity switch, route wires clear of cylinder travel and pinch points. Once power is applied, the proximity switch will show a red LED light on when switch is closed and no LED light when switch is open.

Proximity switch wire connections are shown in figure 10.

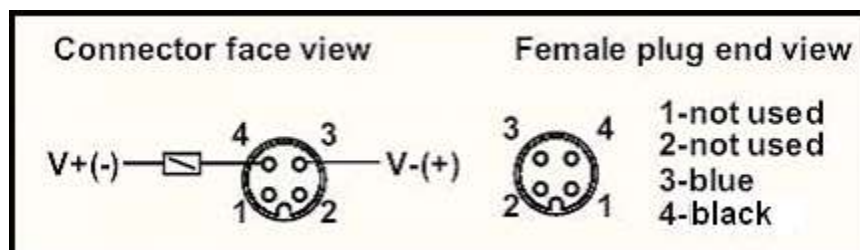

Figure 10 Proximity Switch Connections

## 2.6 Final Pre-operation Checklist

Before operating the HPU, go through the checklist below and verify that each of these steps has been completed.



**CAUTION:** For your safety, complete each of these steps before operating the barrier!

- Verify unit has hydraulic fluid to recommended level.
- Verify control unit is plugged in and cable is routed clear of barrier operation.
- Verify area is clear of personnel and other obstructions.
- Ensure supplied power to HPU matches product requirements.
- Verify electrical hookups are completed per electrical wiring diagram matching particular product.

### 2.6.1 Start up procedure of Hydraulic Pumping units

1. Close all the flow control valves completely.
2. Shift all directional control valves manually to the left.
3. Confirm the reservoir is clean and clear of debris.
4. Install clean, filtered oil into the reservoir.
5. Confirm that the draw line ball is open (below motor)
6. Turn overload protection devices off by pushing the stop button (red)
7. Check the motor rotation by turning the power on at the disconnect switch and manually pushing the motor starter in. (The motor needs to rotate clockwise looking down on motor) Correct if necessary.
8. Turn the unit on by pushing the “START” button on the overload protector.
9. Stop the unit at 500-700PSI via “START/STOP” button.
10. Look for leaks and correct, if necessary.
11. Restart unit and allow it to build pressure. One the pressure is achieved the unit will cut off automatically.
12. Check for leaks and correct, if necessary.

### 2.6.2 Line Purging Procedure after Start-up

1. With all the Flow Control Valves closed, give Lane #1 a *close/up* Command.
2. At each device in Lane #1, attach a small piece of hose (2'-3') to the *close/up* hydraulic line and place open end in a 5 gallon bucket
3. Slowly open the flow control valve for that device. (Oil will begin to flow. Allow approximately 1 quart to flow into the bucket)
4. Close that flow control valve and reconnect the hose to the device.
5. Repeat for all the devices on that directional control valve
6. Repeat for all Lanes of traffic

### 2.6.3 Pressure Adjustment

The system pressure is adjusted by turning the adjustment ring on the pressure switch assembly counterclockwise to increase pressure and clockwise to decrease pressure. With power on and oil in the reservoir, press the start button on the motor starter and monitor the system pressure on the gauge. Standard operation is 1500psi. Adjust using adjustment ring as necessary. See photo below.



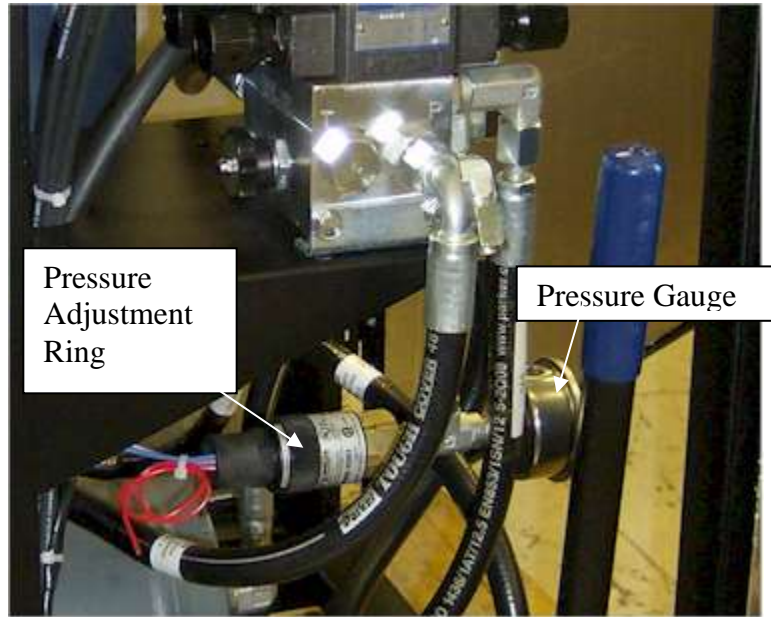

Figure 11 Pressure Adjustment

### 3 TROUBLESHOOTING

The table below provides a general guidance on identifying and correcting any problems with your 611X Series HPU. If you encounter problems that you cannot fix, contact B&B ARMOR and we will gladly work with you to correct them.

#### 611x Series HPU Troubleshooting Guide

The table below provides guidance on identifying and correcting any problems with your 611X series HPU. Please refer to the barrier manual for more detailed troubleshooting guides. If you encounter problems that you cannot fix, contact B&B ARMOR and we will gladly work with you to correct them.

Symptom	Actions
Barrier does not open when commanded on control panel	<ol style="list-style-type: none"> <li>1. Check power</li> <li>2. Check for binding between moving plate and frame. Check connection of linkage between frame and plate. Check for foreign debris.</li> <li>3. Check pressure gauge</li> <li>4. Check overload protector</li> <li>5. Manually open the barrier by depressing the directional control valve to see if problem is mechanical or electrical.</li> <li>6. Check PLC input on pumping unit.</li> <li>7. Check that safeties are clear.</li> <li>8. Check PLC output on pumping unit</li> <li>9. Check push button operation</li> </ol>

Symptom	Actions
Barrier does not close when commanded on control panel	<ol style="list-style-type: none"> <li>1. Check power</li> <li>2. Check for binding between moving plate and frame. Check connection of linkage between frame and plate. Check for foreign debris.</li> <li>3. Check pressure gauge</li> <li>4. Check overload protector</li> <li>5. Manually close the barrier by depressing the directional control valve to see if problem is mechanical or electrical.</li> <li>6. Check PLC input on pumping unit.</li> <li>7. Check that safeties are clear.</li> <li>8. Check PLC output on pumping unit</li> <li>9. Check push button operation</li> </ol>
HPU pump will not build up pressure but is running	<ol style="list-style-type: none"> <li>1. Check power</li> <li>2. Check hydraulic fluid level</li> <li>3. Close pressure relief valve</li> </ol>
HPU pump will not turn on	<ol style="list-style-type: none"> <li>1. Check power</li> <li>2. Check motor overload, press start.</li> <li>3. Check motor starter.</li> <li>4. Check low level switch.</li> <li>5. Check pressure switch.</li> </ol>
Hydraulic unit excessively hot	<ol style="list-style-type: none"> <li>1. Check that the pressure relief valve is closed (fully clockwise).</li> <li>2. Check that the pressure switch is adjusted to shut the motor off before 1900 PSI.</li> <li>3. Check for correct voltages.</li> </ol>
Barrier moves too slowly	<ol style="list-style-type: none"> <li>1. Check for mechanical binds.</li> <li>2. Check flow control valve.</li> <li>3. In extreme cold temperatures, a higher grade hydraulic fluid may be required to keep viscosity constant.</li> </ol>
Traffic indicator light does not change	<ol style="list-style-type: none"> <li>1. Check proper limit switch operation.</li> <li>2. Check bulbs.</li> <li>3. Check PLC outputs.</li> </ol>

## 4 WARRANTY

B&B-ARMR warranties for a period of one year, after delivery F.O.B. plant, unless otherwise specified by Supplier, from failure of operation in ordinary use and against defects due to faulty material or workmanship. Any defective equipment in the Barrier shall be returned to the factory, at Supplier's option, for repair or replacement, and Supplier assumes no responsibility for service at any consumer site. Supplier is in no event responsible for any labor costs under the warranty. Subject to the above limitation, all service, parts, and replacements necessary to maintain the equipment as warranted shall be furnished by the end user. Supplier shall not have any liability under these specifications, other than for repair or replacement as described above for equipment malfunction or equipment failure of any kind, caused for any reason, including, but not limited to unauthorized repairs, improper installation, installation not performed by Supplier personnel, nor by Supplier authorized personnel, failure to perform manufacturer's suggested routine maintenance, modifications, misuse, accident, catastrophe, neglect, natural disaster, act of God or if at any time the power supplied to any part of the Security Barrier falls short or exceeds the rate of tolerance for the equipment.

The exclusive remedy for breach of any warranty by Supplier shall be the repair or replacement at supplier's option, of any defects in the equipment. **IN NO EVENT SHALL THE SUPPLIER OF SECURITY BARRIER BE LIABLE FOR CONSEQUENTIAL OR SPECIAL DAMAGES OR ANY KIND OF DAMAGES TO ANYONE.** Except as provided herein, Supplier makes no warranties or representations to consumer or to anyone else and consumer hereby waives all liability against Supplier as well as any other person for the design, manufacture, sale, installation, and/or servicing of the Security Barrier.

**THE FOREGOING WARRANTIES ARE IN LIEU OF ALL OTHER WARRANTIES EXPRESS OR IMPLIED, INCLUDING THE IMPLIED WARRANTY OF MERCHANTABILITY AND FITNESS FOR A PARTICULAR PURPOSE. NO OTHER WARRANTIES EXIST.**

Any modification or alteration by anyone other than B&B-ARMR will render the warranty herein as null and void.

## 5 APPENDIX

### 5.1 Simplified Standard Hydraulic Diagram

The following figure shows a typical hydraulic schematic for a 611X HPU. The schematic shown is for a single lane barrier system using a cylinder such as an 820 model.

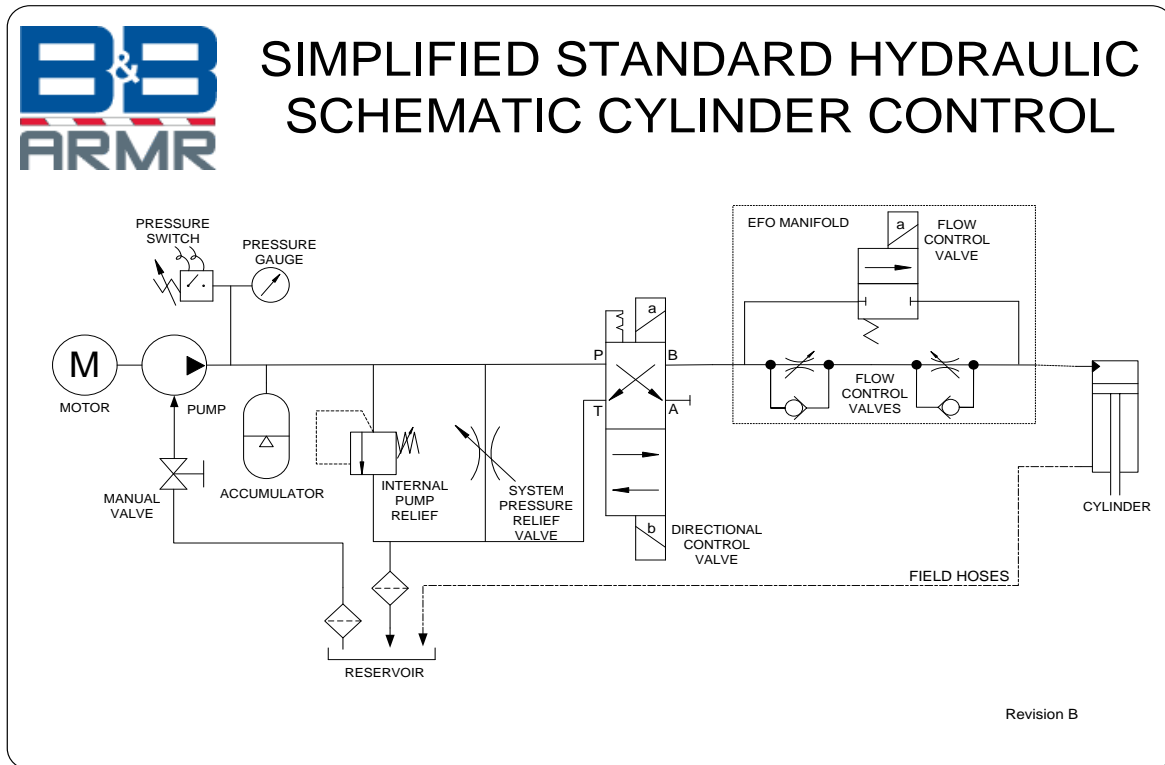

### 5.2 Typical Bollard Hydraulic Flow Diagram

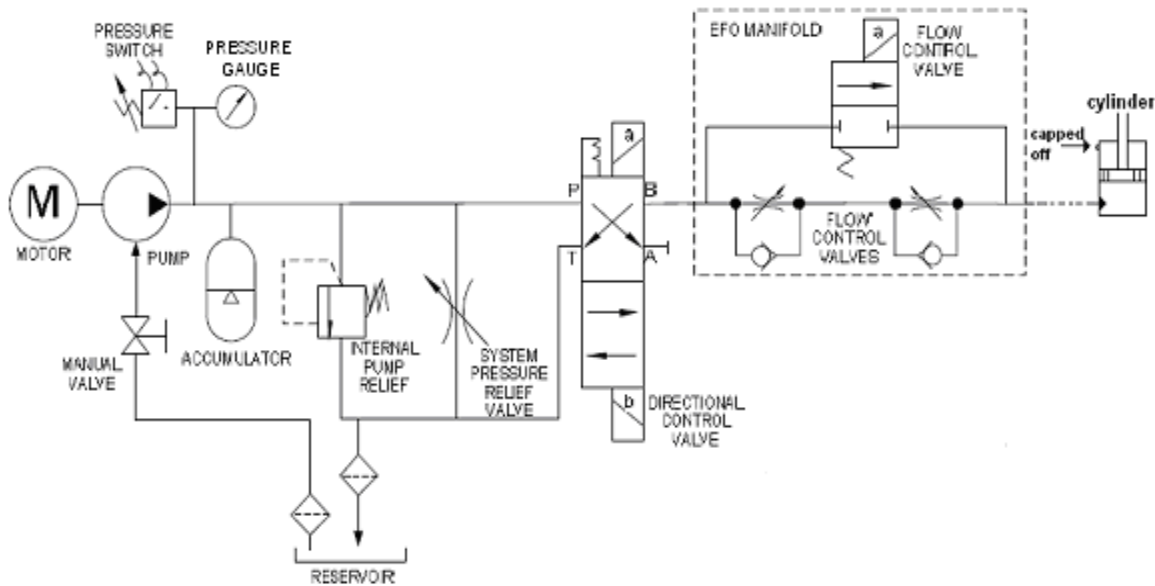

### 5.3 Electrical Field Wiring Diagram

The following figure shows a typical field wiring schematic for a 611X HPU.

