

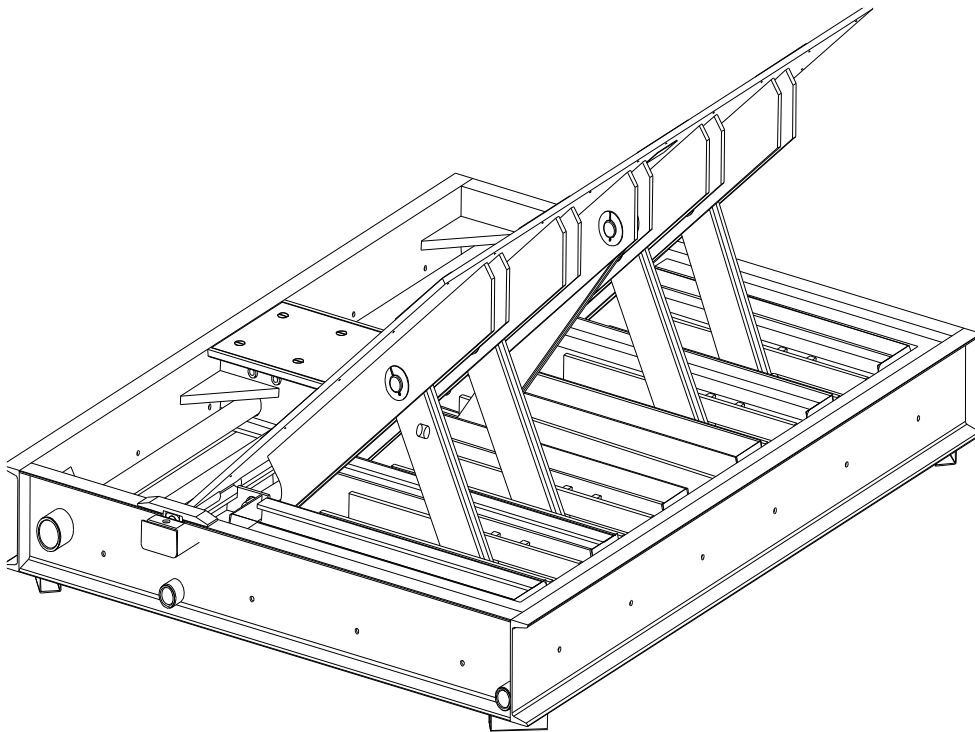

# MODEL 820 SERIES SHALLOW MOUNT PLATE BARRIER

## OPERATIONS & MAINTENANCE MANUAL



### **B&B ARMOR**

#### **Corporate Office & Tech Support:**

5900 S. Lake Forest Drive, Suite 230

McKinney, TX 75070

Phone: (972) 385-7899

Toll Free: (800) 367-0387

Fax: (972) 385-9887

E-mail: [info@bb-armr.com](mailto:info@bb-armr.com)

[techsupport@bb-armr.com](mailto:techsupport@bb-armr.com)

[www.bb-armr.com](http://www.bb-armr.com)

**MADE IN THE USA**



Your safety is extremely important to us. If you have any questions or are in doubt about any aspect of the equipment, please contact us.

# INTRODUCTION

## Welcome!

Congratulations on your purchase of a B&B ARMR vehicle barrier. In addition to providing detailed operating instructions, this manual describes how to install, maintain, and troubleshoot your vehicle barrier. If you require additional assistance with any aspect of your vehicle barrier's installation or operation, please contact us.

With years of experience in all aspects of perimeter security and related disciplines, our products are used throughout the world to control access and to protect people, equipment, and facilities. We offer a broad range of vehicle barrier and related security services:

- Turnkey installations
- Routine barrier preventative maintenance or emergency repairs (including work on non-B&B ARMR products)
- Spare or replacement parts
- Custom designs or special installations
- Equipment upgrades (modernize your old equipment with state-of-the-art hydraulics and control systems)
- Ancillary security equipment such as security guard enclosures, card readers, security lighting, and many other security related products.

## Safety

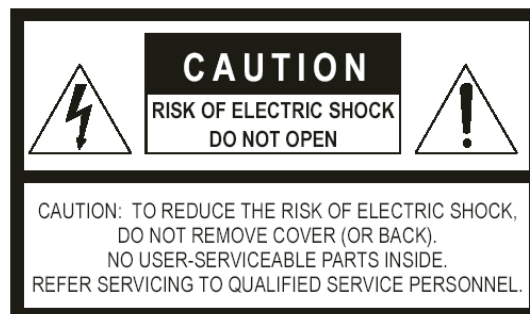

**SYMBOL MEANING:**

The lightning flash with arrowhead symbol, within an equilateral triangle, is intended to alert the user to the presence of non insulated "dangerous voltage" within the product's enclosure that may be of sufficient magnitude to constitute a risk of electric shock to persons.



The exclamation point within an equilateral triangle is intended to alert the user to the presence of important operating and maintenance (servicing) instruction in the literature accompanying the product.

B&B ARMOR does not assume responsibility for injury to persons or property during installation, operation, or maintenance. The user is responsible for correct and safe installation, operation, and maintenance of this equipment. Users must follow the specific instructions and safety precautions located in this manual. In addition they must: Follow the safety standards of the Occupational Safety and Health Administration (OSHA), as well as other applicable federal, state, and local safety regulations and industry standards and procedures. For installation outside the United States, users must also follow applicable international, regional, and local safety standards. Engage only trained and experienced staff to install, operate, and maintain the equipment. Ensure that all repairs are performed correctly using properly trained technicians with the correct tools and equipment.



This barrier comes with a Safety Lock Brace. Use this brace during any maintenance operations when barrier is in the up position. Failure to use this brace during maintenance can result in serious injury or death.

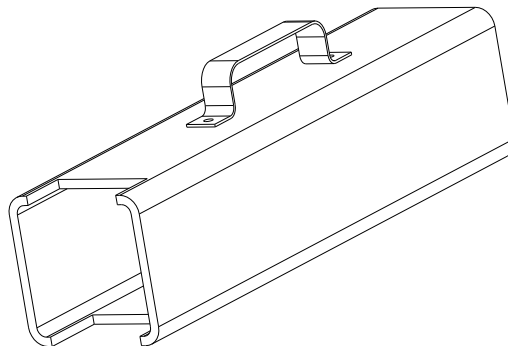

Additional safety devices may be included with this barrier system:

- Vehicle loop detector(s) – Safety loop
- Traffic arms & lights
- IR beams

# How to Contact Us

If you have any questions or experience any problems with your vehicle barrier or if we can help you with any other facility security issues please contact us directly at:

**Corporate/Tech Support:**

**B&B ARMR**

5900 S. Lake Forest Drive, Suite 230

McKinney, TX 75070 USA

Telephone: (972) 385-7899

Toll Free: (800) 367-0387

Fax: (972) 385-9887

**E-mail:** [info@bb-armr.com](mailto:info@bb-armr.com)

[techsupport@bb-armr.com](mailto:techsupport@bb-armr.com)

## Table of Contents

<b>INTRODUCTION .....</b>	<b>ii</b>
<b>Safety.....</b>	<b>ii</b>
<b>How to Contact Us .....</b>	<b>iv</b>
<b>1   ORIENTATION .....</b>	<b>6</b>
1.1 <i>Overview .....</i>	<i>6</i>
<b>2   OPERATION .....</b>	<b>8</b>
2.1 <i>Introduction.....</i>	<i>8</i>
2.2 <i>Control.....</i>	<i>8</i>
2.3 <i>Safety Locks .....</i>	<i>9</i>
2.4 <i>Operating Time .....</i>	<i>9</i>
<b>3   MAINTENANCE.....</b>	<b>10</b>
3.1 <i>Introduction.....</i>	<i>10</i>
3.2 <i>Monthly Inspections .....</i>	<i>10</i>
3.3 <i>Six-Month Inspections.....</i>	<i>11</i>
3.4 <i>Annual Maintenance Inspections .....</i>	<i>12</i>
<b>4   TROUBLESHOOTING.....</b>	<b>13</b>
4.1 <i>Model 820 Troubleshooting Guide.....</i>	<i>13</i>
<b>5   WARRANTY.....</b>	<b>15</b>
<b>6   APPENDIX.....</b>	<b>16</b>
6.1 <i>Exploded View parts List .....</i>	<i>16</i>
6.2 <i>Simplified Standard Hydraulic Diagram.....</i>	<i>17</i>
6.3 <i>Equipment Maintenance Log Form.....</i>	<i>18</i>

# 1 ORIENTATION

## 1.1 Overview

The model 820 vehicle barrier is designed to contain a high-speed vehicle impact and prevent that vehicle from entering a restricted access control area. The barrier consists of a cast in place foundation frame, raising plate with locking linkage, and associated hardware to allow the plate to move from a horizontal position to a raised, secure position with the aid of a hydraulic cylinder. The unit is designed for a shallow excavation, and includes all necessary accesses for drains, hydraulic conduits and electrical services required.

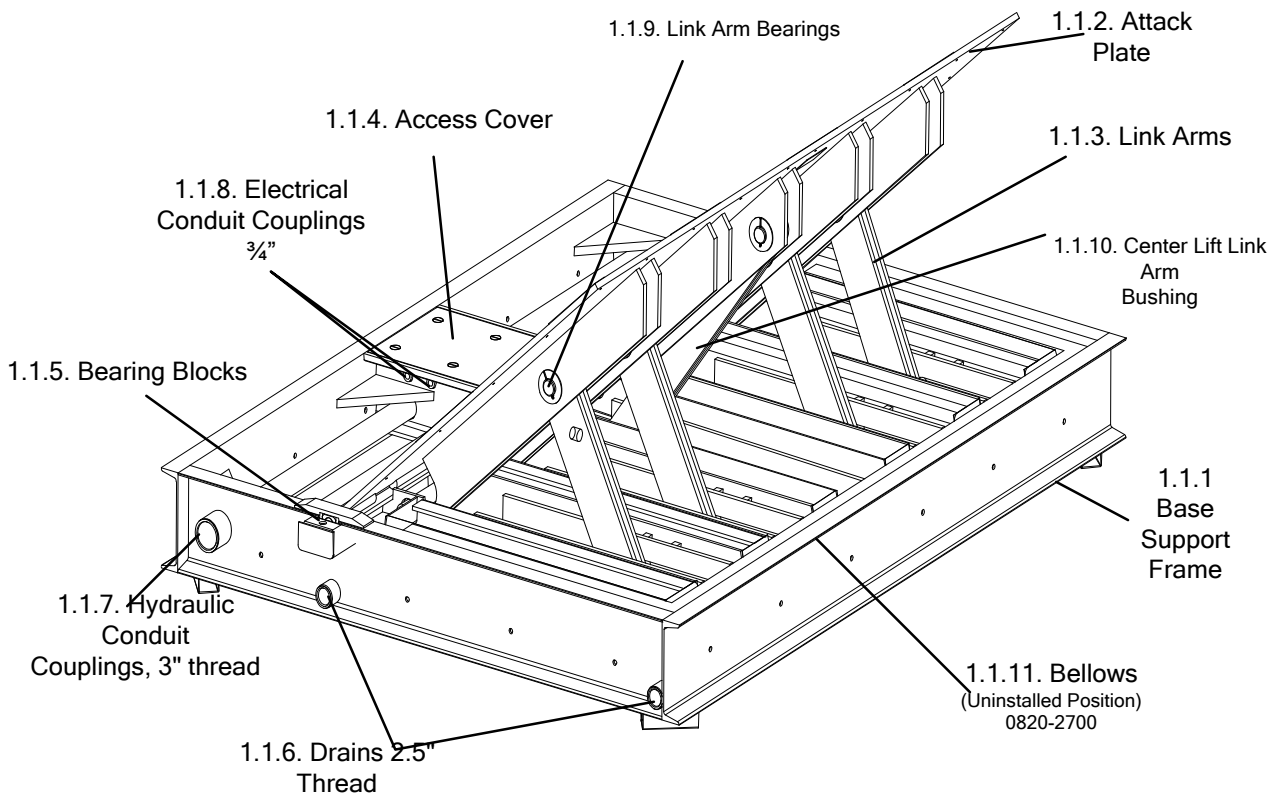

**Figure 1: Model 820 Shallow Mount Plate Barrier**

Figure 1 orients you to the basic components of the Model 820 vehicle barrier:

### 1.1.1 Base Support Frame

The welded steel base support frame is engineered to distribute the crash impact load over a large area of soil surface. Coupled with the specified concrete base, the support frame ensures the barrier does not move on impact.

### 1.1.2 Attack Plate

The attack plate absorbs the impact load of the vehicle and allows a smooth surface for vehicles to roll over when the barrier is in the down position.

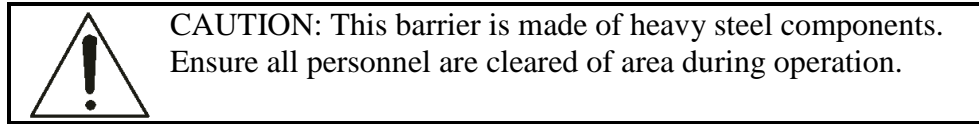

### 1.1.3 Link Arms

The link arms tie the attack plate to the base support frame during impact.

### 1.1.4 Access Cover

The access cover allows maintenance personnel to work on the hydraulic connections without having to be physically under the attack plate. Access to hydraulic cylinder and the proximity switch can be made by removal of the cover with a ½ inch allen wrench.

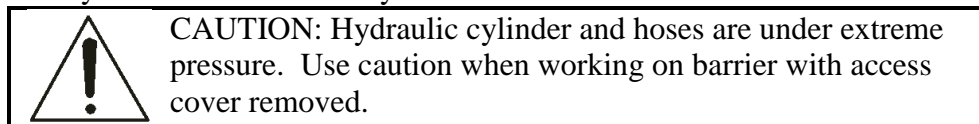

### 1.1.5 Bearing Blocks

The bearing blocks aide in the support and adjustment of the attack plate.

### 1.1.6 Drain Couplings

The 2 ½” drain couplings are provided to allow easy installation of drain pipe to the barrier. It is critical to the operation of the barrier that water drain out from inside the base support structure. Seal all unused drains prior to installation of the base support structure.

### 1.1.7 Hydraulic Conduit Couplings

The 3” hydraulic conduit couplings provide easy interface for conduit to run the hydraulic hoses through. Hydraulic hoses and electrical wires should be run in separate conduits to avoid any chaffing of wires during barrier operation. Seal all unused conduit couplings prior to base support installation.

### 1.1.8 Electrical Conduit Couplings

The ¾” electrical couplings are provided to run all electrical wires. Proximity switch wires should be run in their own conduit to assure no EMI noise affects the proximity switch signals. Seal all unused conduit couplings prior to base support structure installation.

### 1.1.9 Link Arm Bearings

The link arm bearings provide an anti-friction surface for the link arms to rotate on. Some bearings may require lubrication.

### 1.1.10 Center Lift Link Arm

The center link arm provides the drive link to lift the attack plate.

### 1.1.11 Bellows

The bellows provides a soft barrier to ensure debris does not blow or wash into the barrier. Although the bellows keeps the majority of the debris out of the base support frame, routine maintenance is required to keep the barrier clean and free of trash, rocks, and other foreign objects.

### 1.1.12 Options

The Model 820 vehicle barrier is available with a broad array of options and field installed kits. Consult your ordering documentation to determine whether your system has the optional equipment.

- Base support structure heater wire. This optional kit includes the necessary components to add field installed heater strips around the base support frame prior to installation. This is highly recommended for areas where ice or snow may inhibit the performance of the barrier.
- A traffic control gate arm to warn the vehicle operator. This gate arm is positioned on the attack side of the barrier and does not open to allow traffic until the barrier is fully lowered (stowed), and the gate lowers to block traffic before the barrier starts to rise (deploy).
- Red/amber traffic lights. The light remains red if the gate is in any position except fully open.
- Infrared safety beams to detect pedestrian traffic or as an additional vehicle sensing device.

## 2 OPERATION

### 2.1 Introduction

The barrier is moved to the up (or protective) position with a single, center mounted, cylinder designed to push on a pivot arm acting in the reverse motion to the locking linkage. The cylinder is single acting to reduce wear on the hydraulic system. The HPU pushes the attack plate up and gravity pushes the attack plate to the lowered position.

### 2.2 Control

The 820 barrier is controlled by the flow of hydraulic fluid under pressure from the HPU to the cylinder. All control components are connected to the HPU.



## 2.3 Safety Locks

The barrier is provided with a safety lock brace used during servicing to prevent the barrier from accidentally lowering. Install this brace when any maintenance or service is to be performed under the attack plate (See figure 2).

## 2.4 Operating Time

The operating time for the Model 820 barrier is field adjustable at the HPU by varying the hydraulic fluid flow from the HPU as required. Normal operation cycles range from 6-10 seconds for both up and down. Emergency Fast Operation (EFO) is approximately 1.5-2 seconds. The following table illustrates the estimated required flow rates and pressures to operate the Model 820. These values are to use only for pump sizing and initial set-up. Actual times and pressures will vary in field level tests. Model 820 products can be factory adjusted to achieve custom performance if required.

Size (ft)	Estimated Pressure (psi)
6	1650
7	1700
8	1750
9	1800
10	1850
11	1900
12	1950
13	2000
14	2050

Time (Sec)	Actual Required Flow (in <sup>3</sup> /sec)	Actual Required Flow (gal/min)
1	151	39.2
2	75	19.6
3	50	13.1
4	38	9.8
5	30	7.8
6	25	6.5
7	22	5.6
8	19	4.9
9	17	4.4
10	15	3.9
11	14	3.6
12	13	3.3

## 3 MAINTENANCE



Do not attempt repairs unless you are trained and qualified. This vehicle barrier can cause equipment damage and severe injury if it is operated or maintained improperly.

### 3.1 Introduction

The Model 820 Series vehicle barriers are designed to be largely maintenance free. As with any complex electromechanical device however, they must be regularly inspected to ensure they are operating correctly. We recommend a simple monthly visual inspection and a more thorough bi-annual inspection as described below. Please contact B&B ARMOR Technical Service Support for assistance with inspections, maintenance, or repairs if needed.

Component damage is likely if a vehicle strikes the barrier. If this occurs, contact B&B ARMOR. We can help you assess the barrier to make sure there is no hidden damage that will compromise safety or effectiveness and help you determine which components should be replaced.

Additional information associated with the HPU may be found in the HPU user manuals.

### 3.2 Monthly Inspections

We recommend you perform the following visual inspections monthly on the barrier system. An equipment maintenance log is supplied in the appendix to assist in the logging.

- Remove upper bellows mounting hardware and clean out all debris in trough area. Remove any gravel that may have accumulated in and around the bellows area. Do not use high pressure washer on anti-skid surface.
- Inspect and lubricate the acetyl plastic hinge bearing areas with a dry graphite powder, white lithium grease or marine grade grease if necessary. Excessive grease is not required on the acetyl bearings.
- Inspect and lubricate any brass bearing areas with white lithium grease or marine grade grease if necessary.
- Inspect and lubricate the cylinder clevis pin area with white lithium grease or marine grade grease if necessary.
- Inspect the condition of the finish. If rust is present, wire brush and sand the area then paint with a primer and a matching color.
- Vacuum and clean the pumping unit area.
- Check paint and touch up if required.
- Check oil for level, pressure, and condition in the HPU (Recommended oil: Mobil EAL 224)
- If oil is contaminated, report and recommend replacement immediately (Recommended oil: Mobil EAL 224).

- Check barrier for operation through normal cycles.
- Adjust barrier speed to ensure proper operation. Check original submittal documents for normal operating speed for up and down.
- During the opening and closing cycles, verify the barrier operates smoothly and does not bind. Also verify that the barrier does not hit with excessive force when it contacts its full-open or full-closed positions. If necessary, adjust the barrier's speed.
- Check the hydraulic pumping unit for leaks at all points.
- Visually inspect the operation and electrical contacts.
- Tighten electrical contacts if required.
- Check, adjust, and tighten all sensors (limit switches, proximity switches).
- If applicable, check traffic lights and replace any burned bulbs or LEDs.
- Check safety devices (loop, IR, etc.) for proper operation and report any anomalies (if applicable).
- Check the PLC for normal operation of all logic and functions.
- Inspect hinge pin areas for debris and clean.
- Verify bellows is not worn and operates correctly when barrier is closed and opened.
- Inspect the cylinder and report abnormalities.
- Check hoses for wear and report any abnormalities.
- Check the operation of the control panel(s).
- Check the control panel's buttons and lights for proper operation and replace if necessary.
- Update the operation and maintenance log.

### 3.3 Six-Month Inspections

We recommend you perform the following inspections every six months.

- Repeat the visual inspections in the monthly inspection list.
- Turn the master power switch on the control circuit box to the OFF position.
- Inspect the hydraulic system for signs of oil leaks.



**CAUTION:** The hydraulic system when in operation is under extreme pressure. Verify pressure on the barrier is completely relieved prior to removal of any hydraulic fittings.

- Check the hoses for wear or abrasion.
- Check all fittings for tightness.
- Inspect the oil level in the HPU and add if necessary. Typically, the oil level should be 1-1.5 inches below the top of the sight glass on the outside of the reservoir, or about 6 inches below the top of the tank. Environmentally safe oil such as Mobil EAL 224 may be used.
- Inspect the hydraulic oil for dirt or water contamination. If water is present, or oil is light brown in color, correct contamination source and replace oil if necessary.

- Measure the resistance in any traffic loops and log the measurements and report anomalies (if applicable).
- When the inspection is complete, turn the power on and test cycle the barrier to verify operation and control.

### **3.4 Annual Maintenance Inspections**

We recommend you perform the following inspections annually.

- Perform all quarterly maintenance steps.
- Replace the hydraulic fluid and filter.

## 4 TROUBLESHOOTING

The table below provides a general guidance on identifying and correcting any problems with your Model 820 Series vehicle barrier. If you encounter problems that you cannot fix, contact B&B ARMR and we will gladly work with you to correct them.

### 4.1 Model 820 Troubleshooting Guide

The table below provides guidance on identifying and correcting any problems with your Model 820 Series vehicle barrier. Please refer to the HPU O&M manual for more detailed troubleshooting guides referring to the pumping unit. If you encounter problems that you cannot fix, contact B&B ARMR and we will gladly work with you to correct them.

Symptom	Actions
Barrier does not raise up when commanded on control panel	<ol style="list-style-type: none"> <li>1. Check power</li> <li>2. Check overload protector</li> <li>3. Check PLC output on pumping unit</li> <li>4. Check that safeties are clear.</li> <li>5. Check push button operation</li> <li>6. Check PLC input on pumping unit.</li> <li>7. Check pressure gauge</li> <li>8. Manually raise the barrier by depressing the directional control valve to see if problem is mechanical or electrical.</li> <li>9. Check for binding between moving plate and frame. Check connection of linkage between frame and plate. Check for debris.</li> </ol>
Barrier does not close when commanded on control panel	<ol style="list-style-type: none"> <li>1. Check power</li> <li>2. Check PLC output on pumping unit</li> <li>3. Check that safeties are clear.</li> <li>4. Check push button operation</li> <li>5. Check PLC input on pumping unit.</li> <li>6. Check for binding between moving plate and frame. Check connection of linkage between frame and plate. Check for debris.</li> </ol>
HPU pump will not build up pressure but is running	<ol style="list-style-type: none"> <li>1. Check power</li> <li>2. Close pressure relief valve</li> </ol>
HPU pump will not turn on	<ol style="list-style-type: none"> <li>1. Check power</li> <li>2. Check motor overload, press start.</li> <li>3. Check motor starter.</li> <li>4. Check low level switch.</li> <li>5. Check pressure switch.</li> </ol>
Barrier makes noise	<ol style="list-style-type: none"> <li>1. Check linkage between frame and plate. Be sure it is secured</li> </ol>

Symptom	Actions
during operation	<p>and properly lubricated (see maintenance check sheet).</p> <ol style="list-style-type: none"><li>2. Check hinge area for debris and proper lubrication (see maintenance check sheet).</li><li>3. Check hydraulic cylinder clevis pins for lubrication (see maintenance check sheet).</li></ol>
Hydraulic unit excessively hot	<ol style="list-style-type: none"><li>1. Check that the pressure relief valve is closed (fully clockwise).</li><li>2. Check that the pressure switch is adjusted to shut the motor off before 1900 PSI.</li><li>3. Check for correct voltages.</li></ol>
Barrier moves too slowly	<ol style="list-style-type: none"><li>1. Check for mechanical binds.</li><li>2. Check flow control valve.</li><li>3. In extreme cold temperatures, a higher grade hydraulic fluid may be required to keep viscosity constant.</li></ol>
Traffic indicator light does not change	<ol style="list-style-type: none"><li>1. Check bulbs.</li><li>2. Check PLC outputs.</li><li>3. Check proper limit switch operation.</li></ol>

## 5 WARRANTY

BBRSS warranties for a period of one (1) year FOB manufacturing facility, unless otherwise specified by BBRSS in writing, from defects due to faulty material or workmanship. Damage due to handling during shipment and installation are not covered under warranty. BBRSS assumes no responsibility for service at customer site. BBRSS is in no event responsible for any labor costs under the warranty. Subject to the above limitation, all service, parts, and replacements necessary to maintain the equipment as warranted shall be furnished by others. BBRSS shall not have any liability under these specifications, other than for repair or replacement as described above for faulty product material or workmanship. Equipment malfunction or equipment failure of any kind, caused for any reason, including, but not limited to unauthorized repairs, improper installation, installation not performed by BBRSS authorized personnel, incoming supply power is outside the tolerance for the product, failure to perform manufacturer's suggested preventative maintenance, modifications, misuse, accident, catastrophe, neglect, natural disaster, are not under warranty.

The exclusive remedy for breach of any warranty by BBRSS shall be the repair or replacement at BBRSS's option, of any defects in the equipment. **IN NO EVENT SHALL BBRSS BE LIABLE FOR CONSEQUENTIAL OR SPECIAL DAMAGES OR ANY KIND OF PERSONAL DAMAGES.** Except as provided herein, BBRSS makes no warranties or representations to consumer or to anyone else and consumer hereby waives all liability against BBRSS as well as any other person for the design, manufacture, sale, installation, and/or servicing of the Products.

**THE FOREGOING WARRANTIES ARE IN LIEU OF ALL OTHER WARRANTIES EXPRESS OR IMPLIED, INCLUDING THE IMPLIED WARRANTY OF MERCHANTABILITY AND FITNESS FOR A PARTICULAR PURPOSE. NO OTHER WARRANTIES EXIST.**

Any modification or alteration by anyone other than BBRSS will render the warranty herein as null and void.

# 6 APPENDIX

## 6.1 Exploded View parts List

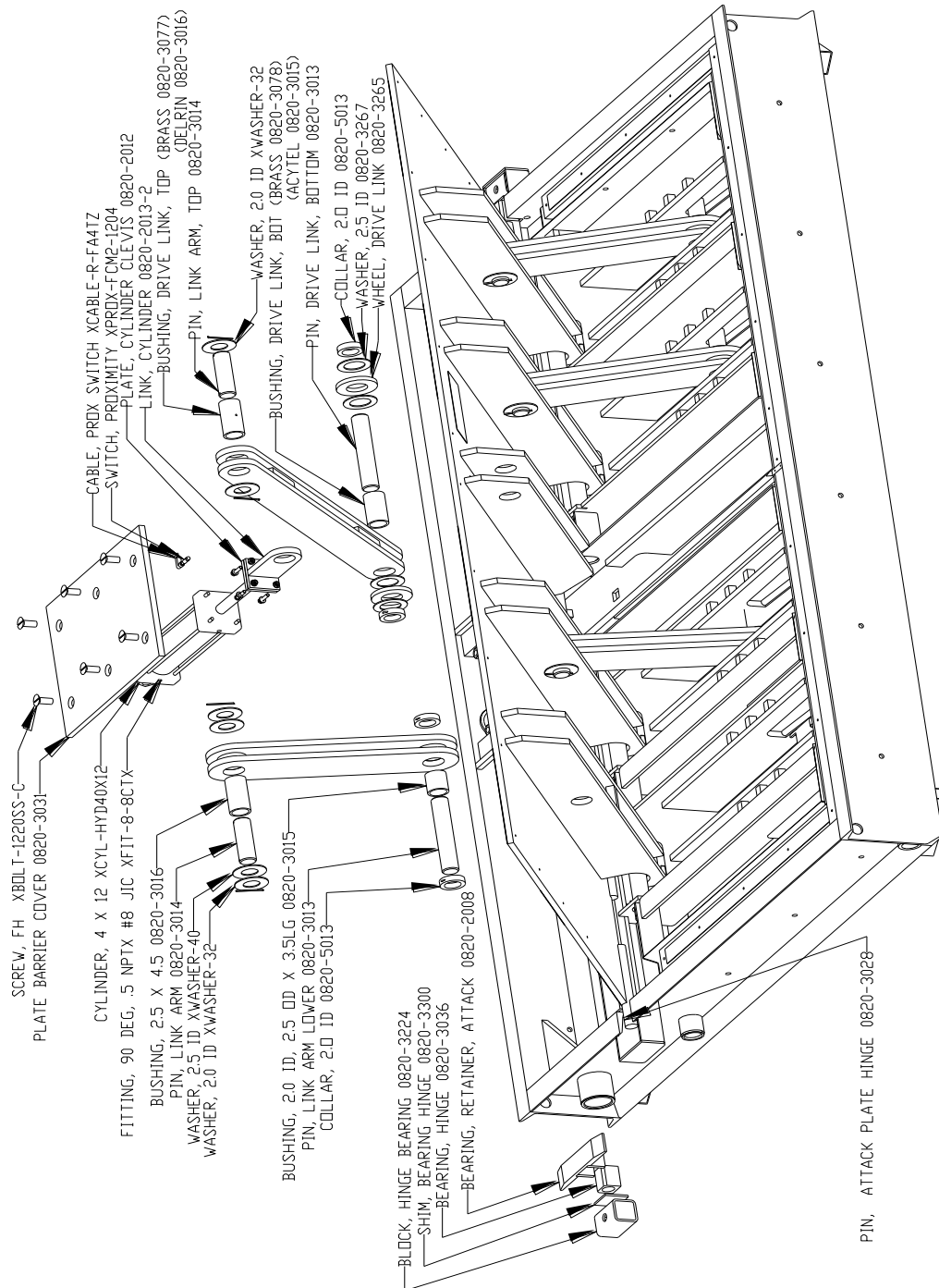



## 6.2 Simplified Standard Hydraulic Diagram

The following figure shows a typical hydraulic schematic for a 611X HPU. The schematic shown is for a single lane barrier system using a cylinder.

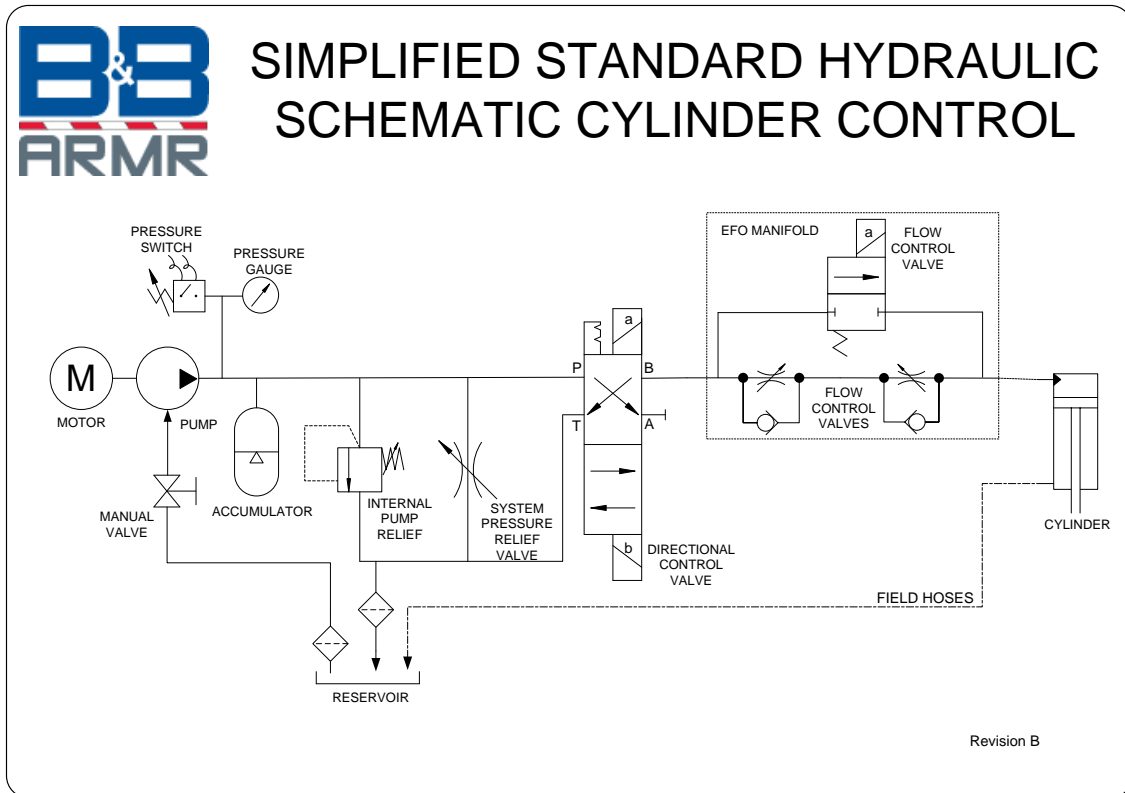

### 6.3 Equipment Maintenance Log Form

Product Type: \_\_\_\_\_

**B&B ARMOR**  
800-367-0387



Location: \_\_\_\_\_

info@bb-armr.com

	Date	Performed By	Checklist Complete	Anomalies	Notes
Jan			Yes No		
Feb			Yes No		
Mar			Yes No		
Apr			Yes No		
May			Yes No		
Jun			Yes No		
Jul			Yes No		
Aug			Yes No		
Sep			Yes No		
Oct			Yes No		
Nov			Yes No		
Year			Yes No		

	Date	Performed By	Checklist Complete	Anomalies	Notes
Jan			Yes No		
Feb			Yes No		
Mar			Yes No		
Apr			Yes No		
May			Yes No		
Jun			Yes No		
Jul			Yes No		
Aug			Yes No		
Sep			Yes No		
Oct			Yes No		
Nov			Yes No		
Year			Yes No		